



VERMONT CHAPTER  
PO Box 302  
Williston, Vt. 05495



# Green Mountain Specifier

November 2001

## NEXT EVENT:

**MONDAY, NOVEMBER 12, 2001**  
1:00 PM – 5:00 PM

**AFTERNOON SEMINAR AND  
MINI-TRADE-SHOW**

**CONCRETE &  
CONSTRUCTION METHODS**

### SPEAKERS

Herman G. Protze, III  
ACI, ASTM, AAA, ASCE, ICRI  
and Peter Craig  
*Construction Investigation and Analysis*

### TIME

Monday, November 12, 2001  
1:00 PM – 5:00 PM

### LOCATION

The Burlington Sheraton  
Williston Road, I-89 Exit 14

### CONTINUING EDUCATION CREDITS

3 direct HSW hours of Learning Units  
for AIA or VT Architect members.

### AGENDA

1:00 Tabletop Mini Trade Show  
1:30 Introductions & Speaker  
3:00 Break & Tabletops  
3:30 Speaker Continues  
5:00 Seminar Ends

### RSVP

By **NOON**, Wednesday, November 7<sup>th</sup>  
to: Jonathan Miller  
e-mail: [campsi@earthlink.net](mailto:campsi@earthlink.net)  
phone: (802) 865-4579

### COSTS

CSI VT Members	<b>\$15</b>
Students	<b>\$10</b>
Non-CSI Members	<b>\$25</b>

Many thanks to John Kamencik and  
Bruce Jacobs, CSI of Don-Vac for  
helping to arrange this presentation.  
Please contact John Kamencik at  
(802) 878-5006, or Jonathan Miller, with  
any questions.

## November 12<sup>th</sup> Program Concrete & Construction Methods – With A Focus on Moisture in Concrete

Our speaker Mr. Herman Protze has more than 35 years of experience successfully resolving unusual and complex situations for clients requiring assistance in areas of forensic engineering and dispute analysis, failure and deficiency evaluations, and construction consulting services. He has extensive applicable background expertise in understanding and application of realistic concrete construction techniques coupled with theoretical knowledge of Portland cement concrete. In-depth understanding of the analysis and evaluation of deteriorated concrete structures, along with knowledge, repair, materials and methods gives him a value readily applied to current projects in our area and around the world.

This is an encore presentation for Mr. Protze. Four years ago the Vermont Chapter CSI and the Subcontractors Association brought Herman in to speak to 120 construction industry members. E-mail Jonathan Miller at [campsi@earthlink.net](mailto:campsi@earthlink.net) to make reservations.

## WE'RE #1

If I may, I'd like to take a moment to praise myself: At the CSI NorthEast Region Conference (see pages 2 & 7 for a recap) the Green Mountain Specifier was awarded the Donald J. Colosano Newsletter Award, given annually to the best newsletter in the Region! Not bad for a publication that didn't exist before this year...thanks to Jonathan Miller, Peter Morris, and everyone else who has helped out. – *Chris Eling, Editor*

## WE WANT YOU ...

...to make a contribution to the Green Mountain Specifier – ideas, articles, letters, advertising or other relevant material (if you're nice, maybe we'll even take irrelevant material). Contact:

Chris Eling, CSI, Editor  
[chris@pmarch.com](mailto:chris@pmarch.com)  
Peter Morris Architect, Inc.  
8 Roundtree Way  
Vergennes VT 05491  
phone: (802) 877-3830  
fax: (802) 877-3972

## Free Money!

### For Construction Site Waste Reduction Planning

As part of its ongoing efforts to help contractors reduce construction waste through advance planning, the Agency of Natural Resources is offering a series of grants totaling \$18,000. The money is slated to develop case studies of Vermont builders who have already saved money through waste prevention, reuse and recycling, and to distribute this information to other builders, with the idea of encouraging contractors around the state to apply these "best practices" from the case studies to their own construction projects. The grant application form can be downloaded from the ANR web site at:

<http://www.anr.state.vt.us/dec/wastediv/recycling/c&d.htm>

Contact Jim Surwilo at 802-241-3481 for a copy of the application form or for more information, or Carolyn Grodinsky, Waste Prevention Coordinator for the Agency of Natural Resources, at (802) 241-3477 or via e-mail: [carolyng@dec.anr.state.vt.us](mailto:carolyng@dec.anr.state.vt.us)

## ***NEXT MONTH:***

### **DECEMBER PROGRAM**

**Afternoon Seminar/Luncheon on:**  
**Division 17: Communications**  
***Impact on Construction in Vermont***

#### **SPEAKERS**

Michael Kirick, CSI, PE  
Jim O'Reilly, Archi-Technology  
Andy Montroll, Riser Management  
Tom McLaughlin, Cellular One

#### **TIME/LOCATION**

Thursday, December 6, 2001  
11:15 AM – 1:45 PM  
At the Burlington Sheraton

#### **CREDITS**

3 direct HSW hours of Learning Units  
for AIA or VT Architect members.

Michael Kirick will give a brief discussion on all the various aspects of the infrastructures relating to telecom and IS/data systems and how they affect the building design process. Also, two additional speakers have confirmed for the line-up: Jim O'Reilly from Archi-Technology will present the latest update in the pending adoption of Div 17 to CSI and give an overview of its organization; and Andy Montroll, senior legal counsel of Riser Management Systems, will present a discussion on the regulatory aspects of the new de-regulated telecom market as it relates to VT, NY, and NH.

There will also be a presentation by Tom McLaughlin of Cellular One giving an overview of the evolving wireless market.

There will be tabletops to browse through as well: before, in-between, and after our speakers.

Thanks to Michael Kirick, CSI, for coordinating this presentation.

## **The President's Corner**

*by Peter D. Morris CSI, RA*

### ***Northeast Region CSI Conference at Basin Harbor***

Northeast Region CSI Conference at Basin Harbor 11 October through 14 October 2001, which was hosted by Vermont and the Boston Chapters of CSI, was a tremendous success thanks to the hard work and organization of Jonathan Miller, Paul Dibona, Howard Levine, and many, many others. Thanks to all of you who attended. The Vermont Chapter plans to submit the program to the Institute seeking a National award and recognition.

### ***Mark 12 November on your Calendar***

The Vermont CSI Chapter with the assistance of Don-Vac Inc. is presenting a seminar on Concrete in Construction on 12 November from 1pm-5pm at the Sheraton. This promises to be a very informative program. See more detailed information elsewhere in the newsletter.

### ***A History of CSI***

A number of years ago, Walter E. Damuck, AIA, CSI, Member Emeritus and Charter Member of the Hartford Chapter (057) and the Housatonic Chapter (110) put together a history of CSI. When I saw Walter at the Northeast Region Conference at Basin Harbor a few weeks ago, I asked him if we could publish the history in our newsletter in installments. "It's for the Chapters to use," he said; and so, starting this month we bring you the first installment, "**In The Beginning**," on page 5.

### ***New Chapter Education Chair and Academic Liaison***

Adam Bortz, CSI, CCS, SCIP, who has recently taught our CDT review course to much acclaim (O.K., the sound of eight students and a grateful Board clapping) has volunteered to be our Chapter Education Chair and our Chapter Academic Liaison. This is wonderful news for the Chapter and will help us to make contacts with professors and students at VTC and Norwich.

### ***A Call for Volunteers***

The Board meets for lunch once a month in the Burlington area. We discuss our outreach and future programs. If you can spare the time for lunch once a month you can help. Contact me at [pm@pmarch.com](mailto:pm@pmarch.com), and we will include you at our next meeting.

### ***New Memberships***

The Vermont Chapter is seeking new members. If you know someone in the industry who should be on our e-mailing list and invited to our programs, please let Jonathan Miller know at [jmilleriaia@earthlink.net](mailto:jmilleriaia@earthlink.net).



**ARCHI-TECHNOLOGY, LLC**

*Building plans for the future*

**James J. O'Reilly**  
Marketing

3445 Winton Place, Suite 222A • Rochester, NY 14623  
(716)424-1952, x32 • Fax (716)424-4239 • Cell (716)314-2567  
[jimo@archi-technology.com](mailto:jimo@archi-technology.com) • [www.archi-technology.com](http://www.archi-technology.com)

## LAST MONTH:

NORTHEAST REGION CSI  
REGION CONFERENCE  
FRIDAY, OCTOBER 12, 2001  
8:30 AM - 5:00 PM

### “GREEN & SUSTAINABLE IN VERMONT”

#### SPEAKERS

Nadav Malin, Environmental Bldg News  
Greg Norris, CSI, Sylvatica  
Donna Leban, AIA, Light-Space-Design  
Jeff Bridges, Energy Savings, Inc.  
Ross Spiegel, RA, FCSI, CCS, CCCA  
CSI Institute President  
Ed Barna, Columnist, Rutland Herald  
Sandra Vitzthum, AIA, Vitzthum Studio

#### LOCATION

Basin Harbor Club  
Basin Harbor Road off Pantton Road  
6 miles west of Vergennes, VT

#### AGENDA

8:30 Keynote: State of Green Bldg  
10:00 Sponsor Break  
10:30 Life Cycle Environmental  
Evaluation of Buildings:  
Tools & Trends  
10:30 Using Daylight to Reduce  
Building Energy Consumption  
12:00 LUNCH  
1:30 Using LEED to Evaluate your  
Project's Greenness  
1:30 Covered Bridges of Vermont  
3:00 Sponsor Break  
3:30 Choosing Materials that Work for  
You and the Environment  
3:30 Straw Bale Construction in the  
Northeast

#### SUMMARY

The Technical Program was a success with 80+/- construction industry members attending the Green & Sustainable seminars on Friday. Many compliments were received on the quality of the speakers and the information imparted. 21 AIA members requested HSW AIA/CEU credits and many other non-AIA architects and certified members filed the credit sheet in their continuing education files. There were 255 people who attended some aspect of the region conference, the largest attendance in region memory since three regions co-hosted a conference in the 1960's.

## The “Pencil And Paper” Mentality

### Part 3 –Drawing Full Size

By Thomas E. Irvin, CCS, CSI, Architect In Private Practice

If you recall the concepts presented in previous articles on shedding the “Pencil And Paper” (P & P) mentality, *Trying A New Approach* and, *Drawing Accurately*, then it's time to send another drafting sacred cow to the slaughter: drawing to scale. “Oh, No!” you say. “I have to draw to scale or my drawings won't fit on the paper!” Take a giant leap backwards, my friend; you're still working with a P & P mentality!

When you begin using CADD, you're putting images on what amounts to a “drawing sheet” of infinite size. No, you can't see the “edges” of the paper (unless you performed certain tasks) but in practice, you've probably discovered that you can draw images anywhere you want to. Once you realize that this electronic “drawing” sheet really has no boundaries, is there any reason *not* to draw everything full size? Of course not!

Full-size drawings are going to be the most accurate ones that can be produced (The exception to this is sloppy or careless CADD operators). If you set drawing precision as high as possible as was recommended previously, the maximum error possible will be multiplied by the *scale factor* of the drawing. For full-size drawings, the scale factor is 1, so any drawing error equals drawing precision factor.

Drawing images full size keeps everything simple. When inserting blocks (which should also be drawn full size) into your drawings, you don't have to specify a scaling factor, just accept the default, which is 1. If you use your drawing as an external reference, you don't have to worry about its size –it shows up full size. There's enough other stuff relating to CADD that'll cause confusion so why add to it? Just follow another simple rule: *Draw everything full size.*

Eventually, you must print (or plot if you prefer) what you draw on paper of a size that can be carried around and used without being awkward or unmanageable. Regardless of the size of the paper it's plotted on, drawings should *still* be drawn at full size because it eliminates some of the confusion about scales, scale factors (a CADD term) and the math computations that are involved in producing scaled images on paper. AutoCad® software has provisions for converting your full-size drawing to an image size suitable for plotting (or printing if you prefer) on a “normal” sized piece of paper. The most basic method is to plot to scale. The simpler method is to plot full size, or 1:1. But we already know that a full-sized image won't fit on a “normal” size piece of paper, didn't we?

It's time to mention a few CADD-unique concepts that usually send P & P'ers wandering aimlessly into the night. AutoCad® software has two drawing modes –Model space and Paper space. (Release 2000 and later call paper space “layout” for their own good reasons.) Model space is where you do your drawing; paper (layout) space is where you compose and plot/print your drawing. To further complicate things, to look at what you drew full size in *model space* in *paper (layout) space*, you need to create something called a *view port* (further aimless wandering!).

The easiest way to visualize the relationship between *model space*, *paper space* and *view ports* is to first assume you exist in paper space. Next, imagine you're looking at a full size title block drawing sheet (any size will do) also in paper space. (P & P folks normally don't have any problem up to

*continued on next page*

**CSI Vermont Chapter:  
FY2002 Officers**

**Mr. Peter D. Morris, CSI, RA  
Chapter President**

Peter Morris Architect  
8 Roundtree Way  
Vergennes, VT 05491  
802-877-3830; 802-877-3972 Fax  
[pm@pmarch.com](mailto:pm@pmarch.com)

**Mr. Jonathan M. Miller, CSI, CCS, CCCA, AIA  
Chapter Secretary / VT Region Director  
Technical, Program & Membership Chairs**

Jonathan M. Miller, Architect  
510 St. Paul Street  
Burlington, VT 05401  
802-865-4579  
[jmilleriaia@earthlink.net](mailto:jmilleriaia@earthlink.net)

**Mr. Robert H. Rand, CSI  
Chapter Treasurer**

87 Cedar Street  
Brandon, VT 05733  
802-247-3729  
[bobhrand@aol.com](mailto:bobhrand@aol.com)

**Mr. John Gant, CSI  
Chapter Vice President**

HCI Craftsman  
30 Tigan Street, P.O. Box 37  
Winooski, VT 05404  
802-655-2621; 802-655-4267 Fax  
[jgant@pleasants.com](mailto:jgant@pleasants.com)

**Mr. Gene Pawlikowski, CSI  
Chapter Vice President  
Awards Chairman**

Trowel Trades Supply Inc.  
71 Troy Avenue  
Colchester, VT 05446  
802-264-1073; 802-655-5841 Fax  
[gpawlikowski@troweltradessupply.com](mailto:gpawlikowski@troweltradessupply.com)

**Mr. Adam F. Bortz, CSI, CCS, SCIP  
Certification & Education Chairs, Academic Liaison**

P.O. Box 65117  
Burlington, VT 05406  
802-864-5953  
[adambortz@aol.com](mailto:adambortz@aol.com)

**Mr. Christopher M. Eling, CSI  
Newsletter Editor / Electronic Comm.**

Peter Morris Architect, Inc.  
8 Roundtree Way  
Vergennes, VT 05491  
802-877-3830; 802-877-3972 Fax  
[chris@pmarch.com](mailto:chris@pmarch.com)

*continued from page 3*

this point.) Behind this drawing sheet (where you can't see it) is model space, where your full-size image resides. Now, this is where the *view port* enters the picture. Use your magic utility knife and cut a rectangle (i.e., view port) in the title block drawing. (Release 2000 users are not limited to a rectangle.) Now, you can "see" your image drawing "through" the view port "window".

The size of images in a view port can adjusted so you tell the software to *zoom* the image to a specific view port *scale factor*. What AutoCad® then does is *reduce* your full size drawing done in model space down to a size that "fits" the title block drawing sheet in the layout (*paper space*). Since the original drawing was full size, the math involved in deciding what view scale factor to use is simply the scale factor of the view port. Everything stays relatively simple – no extra math. Now you have a drawing to plot with a full-sized title block image and a scaled down image showing in the view port.

To sum things up, draw everything full size -your designs, any drawing blocks you create, and all of your title blocks. Use view ports (in layout / paperspace) to scale your design images down to a size that will fit on a title block sheet. In a future article, we'll explain how these drawing files come together to produce the drawing sheet that you plot.

tei

©2001, *tei Architect, Specifications Consultant,*  
[teiararch@chorus.net](mailto:teiararch@chorus.net)

Next month: **Part 4 – Using Drawing Blocks**



The Undisputed World Leader of tile and stone installation systems, floor covering adhesives, and surface preparation systems for over 60 years.

Your local representative for over 10 years  
**Rich Citro, CSI 888-300-4422 x2003**

**WHY ARE WE HERE?**

The Construction Specifications Institute's core purpose is:  
*To improve the process of creating and sustaining the built environment.*

**THIS SPACE FOR RENT**

Our VT chapter Newsletter is published monthly and distributed to over 150 local contractors, architects, product reps, engineers, and other CSI members.

Rates: for 10 issues, full-size ad (1.5"x3.8") \$80; half-size ad \$50

For more information contact The Editor.

# CSI History

## In the Beginning

By Walter E. Damuck, AIA, CSI  
Edited by Peter Morris, RA, CSI

Prior to World War II, society and the process of construction was very different from what we know today. Keeping the story short, WWII's technological advancement forced drastic changes in the burgeoning construction that was its aftermath. New materials, demands for skilled workers who weren't there and cutthroat competition (frequently unscrupulous) created conditions that specifications of that time were not able to cope with.

The simply phrased specifications that only indicated intent (based on the expected pride of workmanship and integrity of the contractor [with nary a thought of loop holes or substitutions]) were GONE. The specs were very weak in organization making it difficult to find what you wanted. The arrangement of the subject matter was at the architect's whim as were the number of divisions (Most specifications had over 90!). Some specifications were arranged to follow the construction process from "Site Clearing" to "Painting"; other were bound in alphabetical order of the concerned activity; and still others tried to keep all the related activities grouped (framing, lathing and plastering).

In early 1947, government Specification Chiefs started complaining about the different practices among the agencies as well as their consultants. A Treasury Department Architectural Chief thought of forming a group of people, who prepared and used specifications, who would bring order out of chaos in construction communication. In September, a meeting of architects, engineers and other in construction disciplines interested in standardizing specifications agreed to form a group known as **The Construction Specifications Institute**. The intent was that business and technical matters would override social aspects.

The toughest job in this formative year was to establish a structure for the "Institute" that would promote growth from the whole nation and develop objectives that would encourage membership. These had to be realistic and far reaching enough to endure without change. The six settled on were:

1. Provide a forum for exchange of information among government and non-government people physically and technically involved in the construction industry – with the objective of improving the quality, clarity, and technical validity of construction specifications;

*continued on page 6*

### Corrections, Retractions, and Apologies

In the October issue, the "Last Month Summary" of the September program (Safe Schools & Door Hardware) included an inaccurate statement: "Watch out for pressure relief valves – they are a one-time protection device, and the door closer no longer operates properly once the valve gives out." This turned out to be a misquote of our speaker, Shelley Hudson of Ingersoll-Rand, who explains her actual position on the issue (see p.8). Also weighing in on the issue is Bill Lawliss of Essex Industries, who took this opportunity to contribute an additional article (see p.9) on door closer hardware. Thanks to both Bill and Shelley for taking the time to contribute.



Lori A. Greene  
AHC/CDC, CCPR  
[lori\\_greene@irco.com](mailto:lori_greene@irco.com)

Shelley Hudson, CCPR  
[shelley\\_hudson@irco.com](mailto:shelley_hudson@irco.com)

Ingersoll-Rand Security & Safety  
Consultants of New England  
77 Wexford Street, PO Box 801  
Needham Heights, MA 02494  
Phone: 781-449-2860 ~ Fax: 781-449-5734

Schlage Von Duprin LCN Steelcraft  
Glynn-Johnson Recognition Systems Locknetics  
Falcon Monarch Dor-O-Matic Ives

**Division 8  
Specifications  
& Consulting**

**"We take the  
hard  
out of  
hardware!"**

### ESSEX Industries

**William Lawliss, CSI, CDT - Architectural Representative**

Phone: 978-388-8593 Fax: 978-388-4689

E-mail: [wlawliss@essexopenings.com](mailto:wlawliss@essexopenings.com)

HM and Wood Door Specifications Hardware Specifications  
AIA/CES Classes Assistance and Support

**"your total opening consultant"**

Thankfully, we have an

#### EDITORIAL POLICY:

The Green Mountain Specifier is published as the official newsletter of the Vermont Chapter of the Construction Specifications Institute. Neither the Editor nor the Chapter assumes responsibility for any alleged errors, and opinions stated are not necessarily those of the Editor, the Chapter's members or leadership, or the Institute.

Contributions to the newsletter are welcome, and should be submitted to the editor by the 24<sup>th</sup> of the month in order to be included in the next issue. Contributions may need to be edited for, among other things, clarity, filesize, and length.

continued from page 5

2. Develop a greater appreciation of the value of the specification as a construction document;
3. Cooperate with, rather than compete against, existing organizations in related fields of endeavor thereby avoiding duplication of work;
4. Interest scholars from architectural and engineering schools in developing practical courses in preparing construction specifications;
5. Develop a means for circulating building research information acquired from valid sources;
6. Develop and maintain current background information on construction materials and methods applicable to construction specifications.

Given this, it was foreseen that CIS's growth must be in an orderly manner, if not, it would enter into areas for which it was not suited. So, concurrently it was determined to define what CSI should not do:

- Establish any semblance of a specification writer's union or similar pressure group interested primarily in self-advancement;
- Emphasize pre-written specification material at the expense of promoting basic principles and suitable background information underlying specification preparation;
- Engage in public lobbying or political activities;
- Attempt to establish the new organization as a super-authority in evaluating construction materials.

The Certificate of Incorporation was signed on March 8, 1948 and filed in Baltimore MD eleven days later. On April 5, 1948 the new 45-member-strong organization had its first official meeting at which Officers and Directors were elected, bylaws adopted and Washington DC was designated as its location. The bylaws established the types of membership as Active and Associated (which was changed to Industry, a classification that restricted leadership assignments). These members resented their position of financially supporting the Institute without voice representation and made it an issue through resolutions at several Annual Conventions. Today's classifications of Professional, Industry, Associate, Intermediate, Student, Retired, Emeritus, and Honorary are more representative of our times. Regardless of the designation, emphasis had been and still should be "Active." We cannot help ourselves, each other, a Chapter, the Institute, and the industry in general without active members.

Coming next month: **Part 2 – CSI Grows**

## Tolerating ADA

CSI members have a great opportunity to contribute to an essential technical document with the development of a Technical Bulletin on construction tolerances for exterior ramps and walking surfaces, as related to meeting ADA Accessibility Guidelines (ADAAG).

There is a very tight turnaround on this project, but historically our members have risen to the challenge when participating in industry advancement.

### **Background**

CSI has been approached by the U.S. Architectural and Transportation Barriers Board, a.k.a. the Access Board ([www.access-board.gov](http://www.access-board.gov)), to develop a technical bulletin on Construction Tolerances.

CSI has decided to set up an online work environment, using its new InfraKnowledge Web site ([www.infraknowledge.org](http://www.infraknowledge.org)) as the vehicle to develop the document. Using that tool, draft documents can be posted online for review and comment by professionals interested in the subject. This would allow CSI to assemble a "virtual" team (called the Document Development Team) of both CSI members and non-members with expertise in the areas needed to develop such a document. Team members would then collaborate on putting together drafts of the sought bulletin, post them for review and comment by the a wide range of interested professionals, and finally integrate all the review/comment input into developing the final document.

### **Your Participation is Needed**

We need interested parties to work together, in a group or individually, to contribute to the development of this document. Interested members can participate by reviewing/commenting on the document as it is developed, and/or be part of the Document Development Team (DDT). The targeted deadline for developing the final draft of the bulletin is April 2002.

An article that provides further information for interested professionals has been edited by the DDT team leader and posted on CSINet (<http://www.csinet.org/technic/infra/ada.htm>). As for the bulletin itself, a "History & Issues" and an "Outline" drafts of the proposed document have been created and are currently posted for reviews/comments online at the "Review!" area of the InfraKnowledge Web site ([www.infraknowledge.org](http://www.infraknowledge.org)).

Please contact me at 800-689-2900 x4739 if you have any questions about this project. Collectively, we advance construction technology.

Ghailan Alsayab. CSI  
Coordinator, Infrastructures Initiative

# CAMP CSI – A Photographic Record



Couldn't have asked for nicer weather, or better color from the foliage.



Kids playing "Simon Says" – Families were welcome, and there were plenty of events for spouses and children.



From left: James Wentworth, NER VP; Graig Davis, current NER President; Peter Morris, VT Chapter President; and Mike Owens, outgoing NER President.



Peter Morris and Jonathan Miller, no doubt receiving valuable advice from Institute President Ross Spiegel.

Kiki Giatis, on the right, and Ted "Ol' Argyle" Healey of the Worcester Chapter CSI.



GoodTimes Central, otherwise known as Rhode Island Chapter HQ – RI will be hosting the conference in Providence next year, and they gave a slick video presentation on what we can expect.



With NER Awards Chair LouAnn Fornataro looking on, Ol' Argyle presents his prestigious C.R.A.P. awards (that's Creative Recognition of Audacious Potential)



In memory of Joseph Zajchowski; a Sugar Maple tree planted on the Basin Harbor grounds.



## Region Awards Given to the Vermont Chapter and its members.....

*Membership Growth Award* – to the Vermont Chapter CSI, *Jonathan M. Miller, CSI, CCS, CCCA, President*...for achieving the largest percentage increase in membership among small chapters in the NorthEast Region from July 1, 2000 to June 30, 2001....Presented to current Chapter President Peter Morris, 13 Oct 2001.

*Citation of Service* – to *Jonathan M. Miller, CSI, CCS, CCCA, AIA*...for service to the NorthEast region in Fiscal Year 2001 as 'Training & Leadership Task Team Co-Chairman'

*Citation of Service* – to *Jonathan M. Miller, CSI, CCS, CCCA, AIA*...for service to the NorthEast region in Fiscal Year 2001 as 'Technical Committee Chairman'

*Donald J. Colosano Newsletter Award* – to the *Vermont Chapter CSI, Christopher M. Eling, Editor*...for publishing the outstanding chapter newsletter in the NorthEast region in Fiscal Year 2001

*Conference Chairman Citation* – to *Jonathan M. Miller, CSI, CCS, CCCA, AIA*...for your dedication, time and focused effort while serving as Co-Chairman of the NorthEast Region FY 2002 Conference Host Committee.

## Pressure Relief Valves - No

by Shelley Hudson, CSI, CCPR, Ingersoll-Rand Co.

The PRV (pressure relief valve) in a door closer relieves the pressure exerted on a door closer's internal valving when a sudden force hits the door during an opening or closing cycle. A PRV protects the door closer during this "event." The PRV was created to enable the closer to survive the event so that it will return to normal and control the door during the next regular cycling. This requirement is known as the European "forward abuse" test.

My point during the presentation was this: is it more important to protect the door closer during this event and sacrifice the other components (which will now be subjected to that force), thus reducing the life expectancy of the other components of this opening? Or, perhaps of more importance: losing the door control during this event puts building occupants at risk if someone is in or near this opening during the event. Liability? Loss of door control means loss of compliance with accessibility requirements, etc.

Door closers which pass the forward-abuse test without using PRV's do exist, thus providing a controlled closing at all times. I contend that everybody benefits from selecting products without the PRV. After all, a controlled closing is why we use door closers in the first place.

I hope this properly explains my position, but should anyone have lingering concerns, please let me know.

[see IRSSC ad on p.5 for contact information]

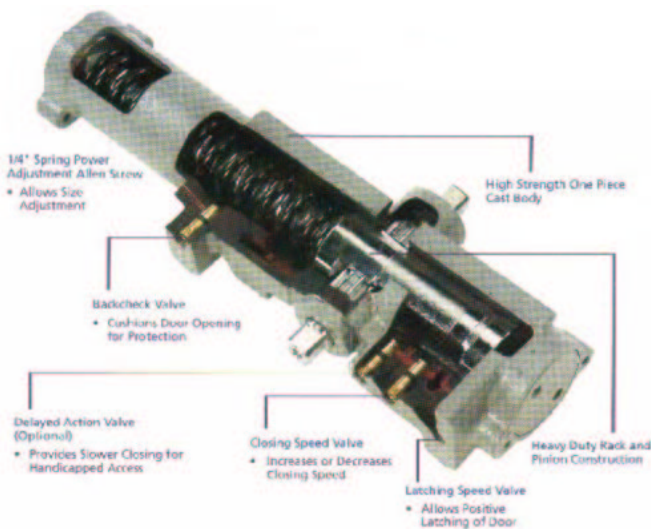

Above: cut-away view of a heavy-duty door closer.

## Pressure Relief Valves - Yes

by Bill Lawliss, CSI, CDT, Essex Industries Inc.

It's the bottom of the ninth, 5 to 4, and your starting pitcher has thrown 120 pitches. Oops, wrong closer. It's fall and while most of us think baseball when someone says bring in the closer, let's talk about a door closer.

A comparison of the two closers, the baseball pitcher and Door Closer, will find some interesting differences and similarities. Differences include one costing \$50 – \$100 vs. \$1,000,000 plus, and one closing a door vs. closing a baseball game. Considering the 2,000,000 minimum cycles for a Grade 1 Door Closer vs. the number of pitches thrown by a baseball pitching closer, one can appreciate the value of a Door Closer at any price. A similarity is both should have strong arms, but the biggest similarity is either closer should function under pressure. When the pressure builds and the game (or door) is on the line will it handle the pressure?

A Pressure Relief Valve (PRV) is a feature offered by many manufacturers of door closers. It is a feature that helps protect the major components of the opening against excessive abuse by, in essence, turning the closer into a shock absorber that absorbs *excess* energy applied to a door. PRV's only operate when excessive force or pressure is applied in pushing the door open or pushing it closed. In either situation, the PRV will open – relieving the excess pressure – yet allowing the closer to operate safely in addition to protecting major components such as the door, the frame, the hinges, and the hinge reinforcements. When the force applied returns to a normal level (non-damaging) the pressure relief valve stops functioning and the door closer returns to normal cycle operation.

If a door is racked or twisted, or if components (including the closer) are damaged, it could keep the door from operating properly or latching. This could cause a security and/or a life safety issue. A PRV does not make a better closer; it makes a better opening. Some in the industry claim that closers with PRV's permit the door to lose control, are dangerous, and should not be allowed. The facts are that they do not cause the closer to lose control, are not dangerous but rather a feature that protects the opening, and almost every closer manufacturer has a pressure relief valve or limiter feature in their backcheck cycle. Manufacturers may give it different names, but it relieves pressure: hence a Pressure Relief Valve.

[Questions? See Essex ad on p.5 for contact information]

# Bring in the Closer...

by Bill Lawliss, CSI, CDT, Essex Industries Inc.

The Door Closer has evolved over the years with technology, new codes, and improved materials, but the basic concept is the same. Its function is to control the opening and closing of a door. If you look at a cut-away closer it's rather an engineering marvel. Basically when the door opens, a spindle moves a plunger, which compresses a heavy-duty spring pushing fluid from the spring side through valves to the opposite side of the Closer body. When the door is released the fluid flows back through valves to the spring side of the closer body, closing the door. These valves are very important since they control different cycles of the door closer operation. By adjusting these valves you can control the backcheck, delayed action, closing cycle, and latching cycle.

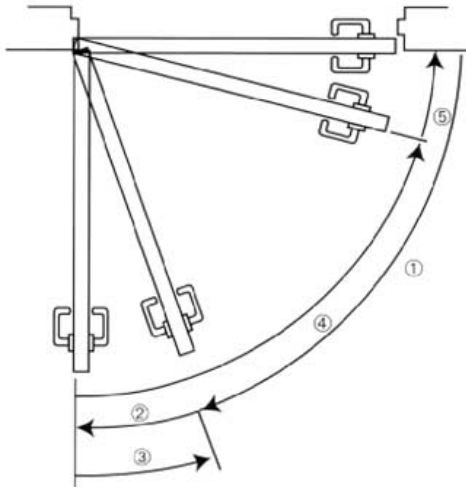

## 1. Opening Cycle

This cycle is the travel period of the door from 0 degrees to approximately 70 degrees. This cycle positions the hydraulic fluid to control the other cycles.

## 2. Backcheck Cycle

Backcheck begins at approximately 70 degrees of the opening cycle to provide a slight cushioning effect and slowing the opening speed of the door. Adjusting the backcheck valve controls the amount of cushioning or pressure. Backcheck is not a replacement for a doorstop.

## 3. Delayed Action Cycle

Delayed Action slows down the closing speed from approximately 90 degrees to 70 degrees. Adjusting the delayed action valve controls additional time for passage through an opening. Delayed Action is an optional feature not offered by a standard closer.

## 4. Closing Cycle

This cycle is the travel period of the door from the full opened position to approximately 15 degrees. Adjusting the speed valve controls the closing speed of the door closer.

## 5. Latching Cycle

Latching Cycle is the travel period of approximately the last 15 degrees of the door closing. Adjusting the latching valve controls the latching speed of the door closer.

Spring power is one other control or adjustment that exist on door closers. By increasing the spring tension you increase the closing power of the door. This is usually referred to as the closer size.

The closer body is usually made from Cast Aluminum Silicon Alloy or Cast Iron; the plunger, spindle, and springs are steel; and the valves can be steel, zinc, or brass. Covers can be plastic or metal and closer arms are forged, wrought, or even threaded steel rod.

With all these choices where do you begin? Since most closers meet ANSI Grade 1 that won't help you make a decision. Cast Silica Aluminum or Cast Iron doesn't differentiate quality either. From a basic engineering position the size of the piston is the most important since it is pushing and displacing the fluid in the closer body.

The next thing to look at is what arms are available. Forged arms are stronger than stamped or threaded rods and availability of specialty arms (Heavy Duty Parallel Arms, Heavy Duty Parallel Stop and/or Holder Arms) can be very important for a heavy duty closer. Brass valves are stronger with larger hex for easier adjustment (larger tool) and can withstand more torquing force than zinc, because brass is a stronger material. Also, a one-piece closer eliminates a potential leaking point.

Features that don't make a door closer close better, but add quality and value: one option is staking or captivating the valves so they cannot be inadvertently backed out. Having interchangeable arms within a closer series adds value to a facility or a project with different applications. Non-handed and multi-sized closers also add value to a facility or a project with different applications or conditions.

The first thing to do when "bringing in the closer" is to evaluate your needs and conditions. Just like in baseball you need to know everything from the score to what you'll be facing. This means specifying closers for the right application and budget, and listing closers that are commercially equal. Determining commercially equal products starts by reviewing manufacturer's specifications, looking at physical samples of the closer and the arms, checking product features, and getting feedback from professionals within your market.

I am an Architectural Representative for ESSEX Industries. I invite anyone associated with CSI to contact me for a tour of the Sargent Manufacturing in New Haven, CT to see the manufacturing facility and products. [see Essex ad on p.5 for contact information]

## 2001 Vermont Chapter CSI Events

- January 11** “Specifying & Designing Lighting”  
Donna Leban, AIA
- February 8** “Code College 2001”  
Bob Patterson, Asst. State Fire Marshal  
Stan Baranowski, Asst. State Fire Marshal
- March 15** “CSI Certifications” at the Windjammer  
Jonathan Miller, CSI, CDT, CCS, AIA
- April 12** “Paint and Coating Systems”  
With tabletops at the Clarion Hotel  
Sponsored by Sherwin-Williams Co.  
Shance Burchill, CSI, ASID
- May 9** “Fireproofing and Firestopping”  
Sponsored by W.R. Grace Co.  
Bob Walsh and George Guanci
- June 6** Joint ASHRAE/CSI Awards Banquet  
“Luau on the Lake” boat cruise on the ‘Spirit of  
Ethan Allen II’ and with Hawaiian Cuisine
- July 12** “Doors, Frames & Door Hardware”  
Basic & Electronic Hardware  
William D. Lawliss, CSI, CDT – Essex Industries
- August 9** “Vermont Brick - Factory Tour” Highgate, VT  
Sponsored by Vermont Brick & Trowel Trades
- September 12** “Codes & Door Hardware for Schools”  
Burlington Sheraton – 11:15 AM to 1:30 PM  
Shelley Hudson, CSI, CCPR – Ingersoll-Rand Co.
- October 12** North East Region CSI Conference – Oct. 11-14  
Basin Harbor Club, Ferrisburgh, VT  
“Green and Sustainable in Vermont”  
Friday Technical Theme [Open to Non-Members]  
Up to 8 hours of HSW Learning Units offered.  
*Jonathan M. Miller, CSI, CCS, AIA*  
*NERCSI Conference Co-Chair*
- November 12** Concrete & Construction Methods  
Herman G. Protze, III, ASTM, ASCE, ICRA  
Peter Craig
- December 6** Division 17 – Communications; and its Impact on  
Vermont Construction, Burlington Sheraton  
Michael P. Kirick, CSI, PE

## **New Members Welcome !**

The Vermont Chapter CSI welcomes back Jeff Caird, CSI, now of Morris-Switzer, and the following new 2001 members:

### October 2001

Steven Benjamin, CSI  
Wilsonart/ CT Plywood Corp.  
Gordon Clements, CSI  
Gordon’s Window Decor  
Daniel Maxon, CSI  
Energy Efficiency Vermont  
Sandra Vitzthum, CSI, AIA  
Vitzthum Studio

### September 2001

Elizabeth Brody, CSI  
Architectural Designer

### August 2001

Kevin Grenier, CSI  
E.H. Danson & Associates

### July 2001

Jerry Wolff, CSI  
Parex, Inc.

### June 2001

Michael Lancione, Student Member  
McGill University, Montreal, Canada

### May 2001

Mitchell Weinberger, CSI  
Acrymax / New England  
Robert Labraccio, CSI  
R K Miles  
Robert O. McEachem Jr., CSI  
Intersource Roofing Sales  
Bryant Bouchard, CSI  
Schluter Systems, Inc.

## **Interested in Joining CSI ?**

Contact any of the chapter officers and we will put you on the road that can connect you to the rest of the construction industry and explain the benefits of chapter membership. You can also check out the institute’s website at [www.csinet.org](http://www.csinet.org) and the region’s website at [www.neregioncsi.org](http://www.neregioncsi.org) for information, links and much more.

Take advantage of the institute’s program to reward each new member that another member sponsors with a \$25 CSI Buck Certificate. CSI Bucks are applicable to any institute publication or event. Contact Jonathan Miller for more information.